

1.25Gbps SFP 1310nm 10km Single-Mode Optical Transceiver

SFP-1G31-10-xx

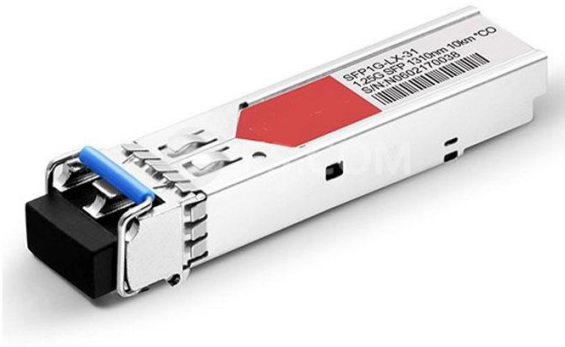

Features

- Data-rate of 1.25Gbps/1.063Gbps operation
- 10km with 9/125 μm SMF \rightarrow Hot-pluggable SFP footprint duplex LC connector Interface
- Class 1 FDA and IEC60825-1 Laser Safety Compliant
- Digital Diagnostic Monitoring \rightarrow Compatible with SFP MSA \rightarrow Compatible with SFF-8472
- +3.3V single power supply and TTL Logic Interface
- Operating case temperature Standard : 0°C to +70°C Extended: -20°C to +85°C Industrial: -40°C to +85°C

Applications

- Gigabit Ethernet
- Fibre Channel Switch Infrastructure
- Other optical transmission systems

Description

The SFP transceivers are high performance, cost effective modules supporting dual data-rate of 1.25Gbps/1.0625Gbps and 10km transmission distance with SMF. The transceiver consists of three sections: a FP laser transmitter, a PIN photodiode integrated with a trans-impedance preamplifier (TIA) and MCU control unit. All modules satisfy class I laser safety requirements. The transceivers are compatible with SFP Multi-Source Agreement (MSA) and SFF-8472. For further information, please refer to SFP MSA.

Specifications

Table 1 - Absolute Maximum Ratings

Parameter	Symbol	Min	Max	Unit
Supply Voltage	Vcc	-0.5	4.5	V
Storage Temperature	Ts	-40	+85	°C
Operating Humidity	-		95	%

Table 2 - Recommended Operating Conditions

Parameter		Symbol	Min	Typical	Max	Unit
Operating Case Temperature	Standard	Tc	0		+70	°C
	Industrial		-40		+85	°C
Power Supply Voltage		Vcc	3.15	3.3	3.45	V
Power Supply Current		Icc			300	mA
Data Rate	Gigabit Ethernet			1.25		Gbps
	Fibre Channel			1.063		

Table 3 - Optical and Electrical Characteristics

Parameter	Symbol	Min	Typical	Max	Unit	Notes
9µm Core Diameter SMF	L		10		km	
Data Rate		-5	1.063/1.25		Gbps	
Transmitter						
Centre Wavelength	λc	1260	1310	1360	nm	
Spectral Width (RMS)	Δλ			3	nm	
Average Output Power	Pout	-9		-3	dBm	1
Extinction Ratio	ER	9			dB	2
Optical Rise/Fall Time (20%~80%)	tr/tf			0.26	ns	
Output Optical Eye	Compliant with IEEE 802.3ah-2004					2
Total Jitter	TJ			0.43	UI	
TX Disable Assert Time	t_off			10	us	
Pout@TX Disable Asserted	Pout			-45	dBm	
Receiver						
Centre Wavelength	λc	1260		1600	nm	
Receiver Sensitivity	Pmin			-21	dBm	4
Receiver Overload	Pmax	-3			dBm	
LOS De-Assert	LOS _D			-22	dBm	
LOS Assert	LOS _A	-42			dBm	
LOS Hysteresis		0.5			dB	5

FibreShop

Notes:

- 1: Output is coupled into a 9/125µm single-mode fibre.
- 2: Filtered, measured with a PRBS 2 7 -1 test pattern @1.25Gbps
- 3: LVPECL logic, internally AC coupled. LVPECL logic, internally AC coupled.
- 4: Minimum average optical power measured at BER less than 1E-12, with a 2 7 -1 NRZ PRBS and ER=9dB.
- 5: Eye Pattern Mask
- 6: LOS Hysteresis

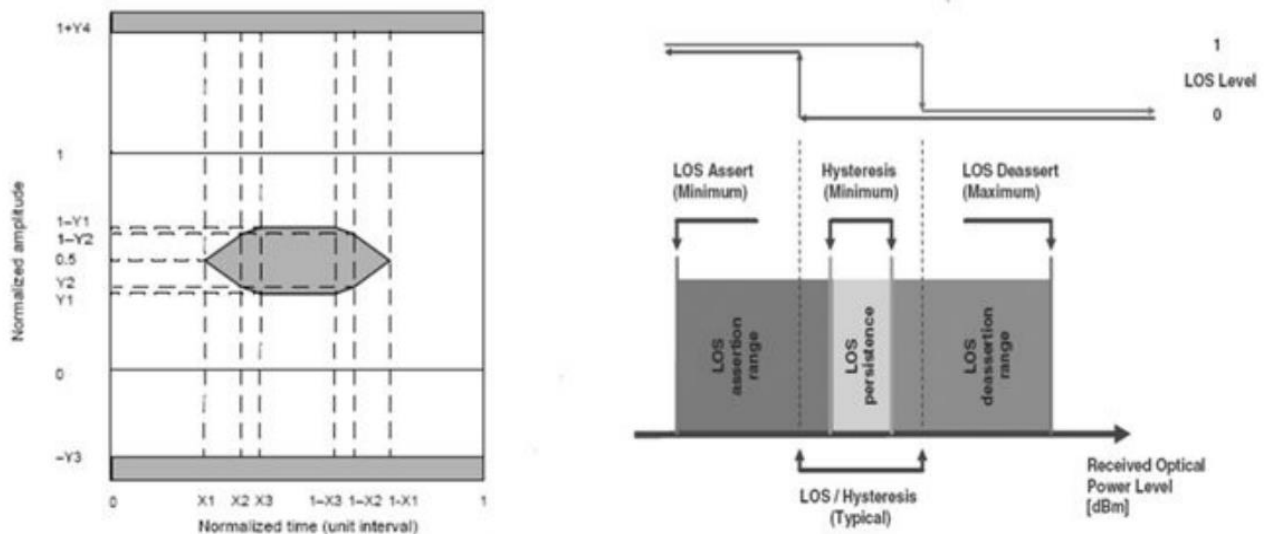

Functional Description of Transceiver

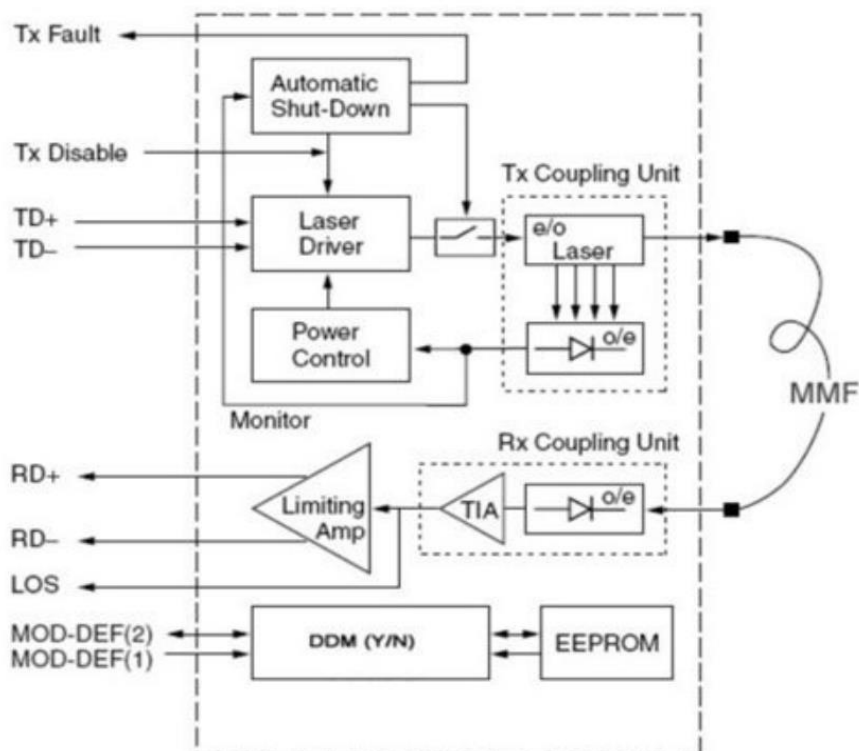

SFP Transceiver Electrical Pad Layout

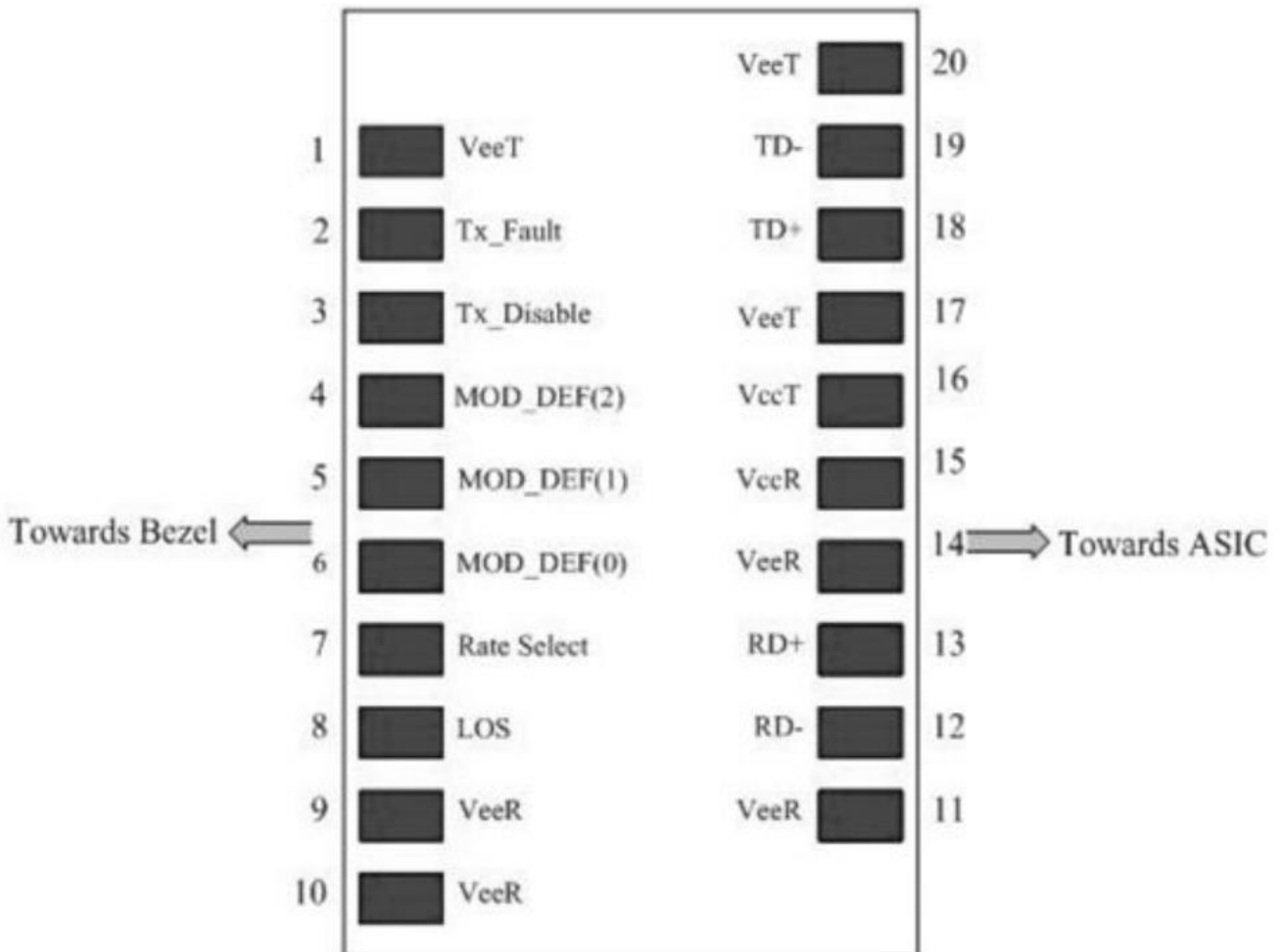
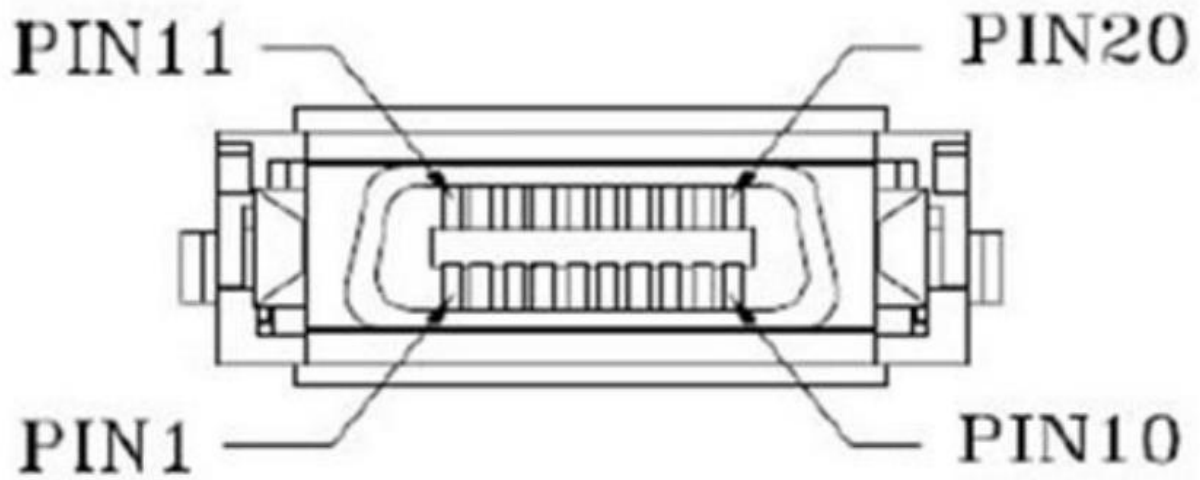

Pin	Signal Name	Description	Plug Seq.	Notes
1	VEET	Transmitter Ground	1	
2	TX FAULT	Transmitter Fault Indication	3	Note 1
3	TXDISABLE	Transmitter Disable	3	Note 2
4	MOD_DEF(2)	SDA Serial Data Signal	3	Note 3
5	MOD_DEF(1)	SCL Serial Clock Signal	3	Note 3
6	MOD_DEF(0)	TTL Low	3	Note 3
7	Rate Select	Not Connected	3	
8	LOS	Loss of Signal	3	Note 4
9	V _{EER}	Receiver ground	1	
10	V _{EER}	Receiver ground	1	
11	V _{EER}	Receiver ground	1	
12	RD-	Inv. Received Data Out	3	Note 5
13	RD+	Received Data Out	3	Note 5
14	V _{EER}	Receiver ground	1	
15	V _{CCR}	Receiver Power Supply	2	
16	V _{CCT}	Transmitter Power Supply	2	
17	V _{EET}	Transmitter Ground	1	
18	TD+	Transmit Data In	3	Note 6
19	TD-	Inv. Transmit Data In	3	Note 6
20	V _{EET}	Transmitter Ground	1	

Notes:

Plug Seq.: Pin engagement sequence during hot plugging.

1) TX Fault is an open collector output, which should be pulled up with a 4.7k~10kΩ resistor on the host board to a voltage between 2.0V and Vcc+0.3V. Logic 0 indicates normal operation; Logic 1 indicates a laser fault of some kind. In the low state, the output will be pulled to less than 0.8V.

2) TX Disable is an input that is used to shut down the transmitter optical output. It is pulled up within the module with a 4.7k~10kΩ resistor. Its states are:

Low (0 to 0.8V):	Transmitter on
(>0.8V, < 2.0V):	Undefined
High (2.0 to 3.465V):	Transmitter Disabled
Open:	Transmitter Disabled

3) Mod-Def 0, 1, 2. These are the module definition pins. They should be pulled up with a 4.7k~10kΩ resistor on the host board. The pull-up voltage shall be VccT or VccR.

Mod-Def 0 is grounded by the module to indicate that the module is present

Mod-Def 1 is the clock line of two wire serial interface for serial ID

Mod-Def 2 is the data line of two wire serial interface for serial ID

4) LOS is an open collector output, which should be pulled up with a 4.7k~10kΩ resistor. Pull up voltage between 2.0V and Vcc+0.3V. Logic 1 indicates loss of signal; Logic 0 indicates normal operation. In the low state, the output will be pulled to less than 0.8V.

FibreShop

5) RD-/+ : These are the differential receiver outputs. They are internally AC-coupled 100 differential lines which should be terminated with 100Ω (differential) at the user SERDES.

6) TD-/+ : These are the differential transmitter inputs. They are internally AC-coupled, differential lines with 100Ω differential termination inside the module.

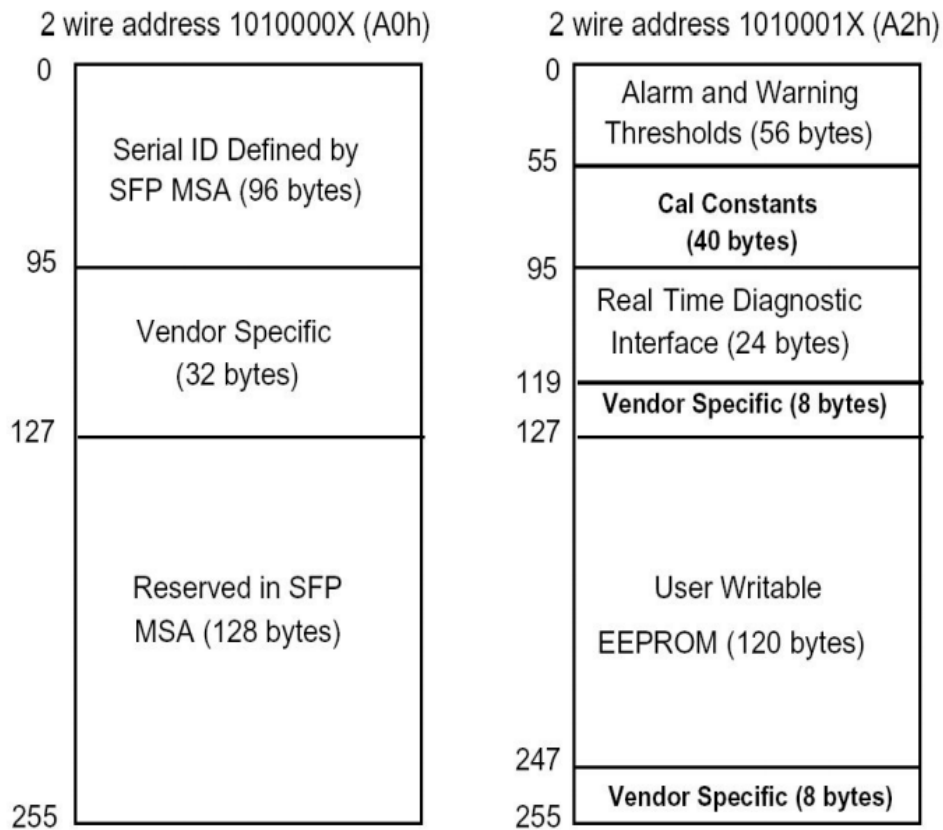

EEPROM Serial ID Memory Contents

Add.	Size (Bytes)	Name of Field	Hex	Description
BASE ID FIELDS				
0	1	Identifier	3	SFP
1	1	Ext. Identifier	4	SFP function is defined by serial ID only
2	1	Connector	7	LC Connector
3-10	8	Transceiver	XX ^(note)	Transmitter Code
11	1	Encoding	01	8B10B
12	1	BR, Nominal	0D	1.25Gbps
13	1	Reserved	00	Transceiver Transmit Distance
14	1	Length (9μm) km	0A/0F/14/1E/28	
15	1	Length(9μm) 100m	64/96/C8/FF/FF	
16	1	Length (50μm) 10m	00	
17	1	Length(62.5μm)10m	00	
18	1	Length (Copper)	00	Not Compliant
19	1	Reserved	00	Vendor name (ASCII)
20-35	16	Vendor name	XX XX XX XX XX XX XX XX ^(note) 20 20 20 20 20 20 20 20	
36	1	Reserved	00	

FibreShop

37-39	3	Vendor OUI	00 00 00	
40-35	16	Vendor PN	XX XX XX XX XX XX XX XX XX XX XX XX XX XX XX XX	Transceiver part number
56-59	4	Vendor rev	XX XX XX XX ^(note)	ASCII (31 30 20 20 means 1.0 revision)
60-61	2	Wavelength	05 1E	1310nm
62	1	Reserved	00	
63	1	CC_BASE	Check Sum (Variable)	Check Code for Base ID Fields
EXTENDED ID FIELDS				
64-65	2	Options	00 1A	TX_DISABLE, TX_FAULT and Loss of Signal implemented.
66	1	BR, max	00	
67	1	BR, min	00	
68-83	16	Vendor SN	XX XX XX XX XX XX XX XX ^(note) 20 20 20 20 20 20 20 20	Serial Number of transceiver (ASCII). For example "B000822".
84-91	8	Date Code	XX XX XX XX XX XX XX XX ^(note9)	Manufactory Date Code. For example "080405".
92	1	Diagnostic Monitoring Type	XX ^(note9)	Digital Diagnostic Monitoring Implemented
93	1	Enhanced Options	XX ^(note)	Optional Flags
94	1	SFF_8472 Compliance	XX ^(note)	01 for Rev9.3 SFF-8472
95	1	CC_EXT	Check Sum (Variable)	Check Sum for Extended ID Field
VENDOR SPECIFIC ID FIELDS				
96-127	32	Vendor Specific	Read Only	Depends on Customer Information
128-255	128	Reserved	Read Only	

Note: The "XX" byte should be filled in according to practical case. For more information, please refer to the related document of SFP Multi-Source Agreement (MSA).

FibreShop

Ordering Information

Part No.	Data Rate (Gbps)	Wavelength (nm)	Connector Type	Transmission Distance (km)	Operating case temperature (°C)	Digital Diagnostics
SFP-1M31-10-xx	1.25	1310	LC	10	0 to +70	No
SFP-1M31-10D-xx	1.25	1310	LC	10	0 to +70	Yes
SFP-1M31-10E-xx	1.25	1310	LC	10	-20 to +85	No
SFP-1M31-10ED-xx	1.25	1310	LC	10	-20 to +85	Yes
SFP-1M31-10I-xx	1.25	1310	LC	10	-40 to +85	No
SFP-1M31-10ID-xx	1.25	1310	LC	10	-40 to +85	Yes

Notes:

xx means compatible brand. (For example: CO= Cisco, JU=Juniper, FD=Foundry, EX=Extreme, NE=Netgear,etc.)

For more information please contact

FibreShop

601 – 603 Flinders Street

Townsville Qld

Australia

Tel: +61 74728 4568

Fax: +61 74725 1888

or visit www.fibreshop.com.au

All statements, technical information, and recommendations related to the products herein are based upon information believed to be reliable or accurate. However, the accuracy or completeness thereof is not guaranteed, and no responsibility is assumed for any inaccuracies. Please contact FibreShop for more information.